

Safety in the Chemistry Laboratory

Everyone who works in a chemistry laboratory should follow these safety precautions.

1. Wear safety goggles and a laboratory apron in the laboratory at all times.
2. Shoes must be worn in the laboratory. Avoid wearing overly bulky or loose fitting clothing. Remove any dangling jewelry.
3. Conduct only assigned experiments, and do them only when your teacher is present.
4. Know the locations of safety equipment such as eyewash fountains, fire extinguishers, emergency shower, and fire blanket. Be sure you know how to use the equipment.
5. Do not chew gum, eat, or drink in the laboratory. Never taste any chemicals. Keep your hands away from your face when working with chemicals.
6. Wash your hands with soap and water at the end of each laboratory exercise.
7. Read all of the directions for a laboratory procedure before proceeding with the first part. Reread each instruction before you do it.
8. Notify your teacher immediately if any chemicals, such as concentrated acid or base, are spilled.
9. Report all accidents, no matter how slight, to the teacher immediately.
10. Pin or tie back long hair and roll up loose sleeves when working with flames.
11. Do not leave a lighted burner unattended.
12. Use a hot plate instead of an open flame whenever a flammable liquid is present.
13. Read the label on a reagent bottle carefully *before* using the chemical. After removing the chemical from the bottle, check to make sure that it is the correct chemical for that procedure.
14. To avoid contamination, do not return unused chemicals to a reagent bottle. Similarly, never put a pipet, spatula, or dropper into a reagent bottle. Instead, pour some of the reagent into a small clean beaker and use that as your supply.
15. Do not use chipped or cracked glassware. Discard it according to your teacher's instructions.
16. When diluting an acid, *always* pour the acid slowly into water with stirring to dissipate the heat generated. **CAUTION:** *Never pour water into a concentrated acid.*
17. When heating a liquid in a test tube, turn the mouth of the test tube away from yourself and others.
18. Clean up spills and broken glass immediately. Leave your work area clean at the end of the laboratory period.

Laboratory Hazards

You should be aware of possible hazards in the laboratory and take the appropriate safety precautions. By doing so, the risks of doing chemistry can be minimized. This safety section is intended to acquaint you with the hazards that exist in the laboratory and to indicate how you can avoid these hazards. In addition, information is provided on what to do if an accident should occur.

Thermal Burns

A thermal burn can occur if you touch hot equipment or come too close to an open flame. You can prevent thermal burns by being aware that hot and cold equipment look the same. If a gas burner or hot plate has been used, some of the equipment nearby may be hot. Hold your hand near an item to feel for heat before touching it. Treat a thermal burn by *immediately* applying cold running water to the burned area. Continue applying the cold water until the pain is reduced. This usually takes several minutes. In addition to reducing pain, cooling the burned area also serves to speed the healing process. Greases and oils should not be used to treat burns because they tend to trap heat. Medical assistance should be sought for any serious burn. **Notify your teacher immediately if you are burned.**

Chemical Burns

A chemical burn occurs when the skin or a mucous membrane is damaged by contact with a substance. The Materials section of each exercise indicates which substances can cause chemical burns. **C** stands for corrosive. It indicates that the chemical can cause severe burns. **I** stands for irritant. It indicates that the chemical can irritate the skin and the membranes of the eye, nose, throat, and lungs. Chemicals that are marked **C** or **I** should be treated with special care. Chemical burns can be severe. Permanent damage to mucous membranes can occur despite the best efforts to rinse a chemical from the affected area.

The best defense against chemical burns is *prevention*. **Without exception, wear safety goggles during all phases of the laboratory period—even during clean-up.** Should any chemical splash in your eye, immediately use a continuous flow of running water to flush your eye for a period of 20 minutes. Call for help. If you wear contact lenses, remove them immediately. This is especially crucial if the chemical involved is an acid or base. It can concentrate under the lens and cause extensive damage. Wear a laboratory apron and close-toed shoes (no sandals) to protect other areas of your body. If corrosive chemicals should contact your exposed skin, wash the affected area with water for several minutes.

An additional burn hazard exists when concentrated acids or bases are mixed with water. The heat released in mixing these chemicals with water can cause the mixture to boil, spattering corrosive chemical. The heat can also cause nonpyrex containers to break, spilling corrosive chemical.

To avoid these hazards, follow these instructions: Always add acid or base to water, very slowly and with stirring, never the reverse. One way to remember this critical advice is to think of the phrase, “pouring acid into water is doing what you ought-er”.

Cuts from Glass

Cuts occur most often when thermometers or pieces of glass tubing are forced into rubber stoppers. Prevent cuts by using the correct technique for this procedure. The hole should be lubricated with glycerol or water to facilitate the movement of the glass tubing. The glass should not be gripped directly with the hands, but rather, by means of paper towels. The towels will protect your hands if the glass should break. Use a gentle twisting motion to move the tube smoothly into the stopper.

Avoid cuts from other sources by discarding chipped and cracked glassware according to your teacher's instructions. If you should receive a minor cut, allow it to bleed for a short time. Wash the injured area under cold running water, and notify your teacher. Serious cuts and deep puncture wounds require immediate medical help. Notify your teacher immediately. While waiting for assistance, control the bleeding by applying pressure with the finger tips or by firmly pressing with a clean towel or gauze.

Fire

A fire may occur if chemicals are mixed improperly or if flammable materials come too close to a burner flame or hot plate. When using this equipment, prevent fires by tying back long hair and loose fitting clothing. Do not use a burner when flammable chemicals are present. These chemicals are designated with the symbol **F** in the materials section for each exercise. Use a hot plate as a heat source instead of a burner when flammable chemicals are present.

If hair or clothing should catch fire, DO NOT run, because running fans a fire. Drop to the floor and roll slowly to smother the flames. Shout for help. If another person is the victim, get a fire blanket to smother the flames. If a shower is nearby, help the victim to use it.

In case of a fire on a laboratory bench, turn off all accessible gas outlets and unplug all accessible appliances. A fire in a container may be put out by covering the container with a nonflammable object. It could also be smothered by covering the burning object with a damp cloth. If not, call for a fire extinguisher. Spray the base of the fire with foam from the extinguisher. **Caution:** *Never direct the jet of a fire extinguisher into a person's face.* Use a fire blanket instead. If a fire is not extinguished quickly, leave the laboratory. Crawl to the door if necessary to avoid the smoke. Do not return to the laboratory.

Poisoning

Many of the chemicals used in the experiments in this manual are toxic. Such chemicals are identified in the materials sections with the symbol **T**.

You should do several things to prevent poisoning. Never eat, chew gum or drink in the laboratory. Do not touch chemicals. Clean up spills. Keep your hands away from your face. In this way you will prevent chemicals from reaching your hands, mouth, nose or eyes.

In some cases, the detection of an odor is used to indicate that a chemical reaction has taken place. It is important to note, however, that many gases are toxic when inhaled. If you must detect an odor, use your hand to waft some of the gas toward your nose. Sniff the gas instead of taking a deep breath. This will minimize the amount of gas sampled.

Safety Symbols

Take appropriate precautions whenever any of these safety symbols appears next to the instructions in a procedure.



Eye Hazard

- Wear safety goggles.



Corrosive Substance Hazard

- Wear safety goggles and laboratory apron.
- Do not touch chemicals.



Fire Hazard

- Tie back hair and loose clothing.
- Do not use a burner near flammable materials.



Poison Hazard

- Do not chew gum, drink, or eat in the laboratory.
- Keep your hands away from your face.



Inhalation Hazard

- Avoid inhaling this substance.



Thermal Burn Hazard

- Do not touch hot equipment.



Breakage Hazard

- Do not use chipped or cracked glassware.
- Do not heat the bottom of a test tube.



Disposal Hazard

- Dispose of this chemical only as directed.

Emergency Procedures

Report any injury, accident, or spill to your teacher immediately. Know the location of the closest eye wash, fountain, fire blanket, fire extinguisher, and shower.

Situation	Safe Response
Burns	Immediately flush with cold water until the burning sensation subsides.
Fainting	Provide fresh air (for instance, open a window). Move the person so that the head is lower than the rest of the body. If breathing stops, use artificial resuscitation.
Fire	Turn off all gas outlets. Unplug all appliances. Use a fire blanket or fire extinguisher to smother the fire. Caution: Do not cut off a person's air supply.
Eye Injury	Immediately flush the eye with running water. Remove contact lenses. Do not allow the eye to be rubbed if a foreign object is present in the eye.
Minor Cuts	Allow to bleed briefly. Wash with soap and water.
Poisoning	Note what substance was responsible. Alert teacher immediately.
Spills on skin	Flush with water.

Student Equipment

At the beginning and end of the year, record how many of each item are in your equipment drawer.

Item	Quantity Checked In	Quantity Checked Out	Breakage
beaker, 100-mL			
beaker, 250-mL			
beaker, 400-mL			
ceramic plate			
crucible, with cover			
crucible tongs			
dropper pipet (eye dropper)			
evaporating dish			
flask, Erlenmeyer, 125-mL			
flask, Erlenmeyer, 250-mL			
forceps			
funnel			
graduated cylinder, 10-mL			
graduated cylinder, 25-mL			
graduated cylinder, 100-mL			
laboratory apron			
mortar and pestle			
safety goggles			
screw clamp or pinch clamp			
spatula, scoopula			
stirring rod and policeman			
test tube, 13 × 100 mm (small)			
test tube, 20 × 150 mm (medium)			
test tube holder			
thermometer (− 10°C to 110°C)			
triangle			
watch glass			
wire gauze			

Laboratory Equipment

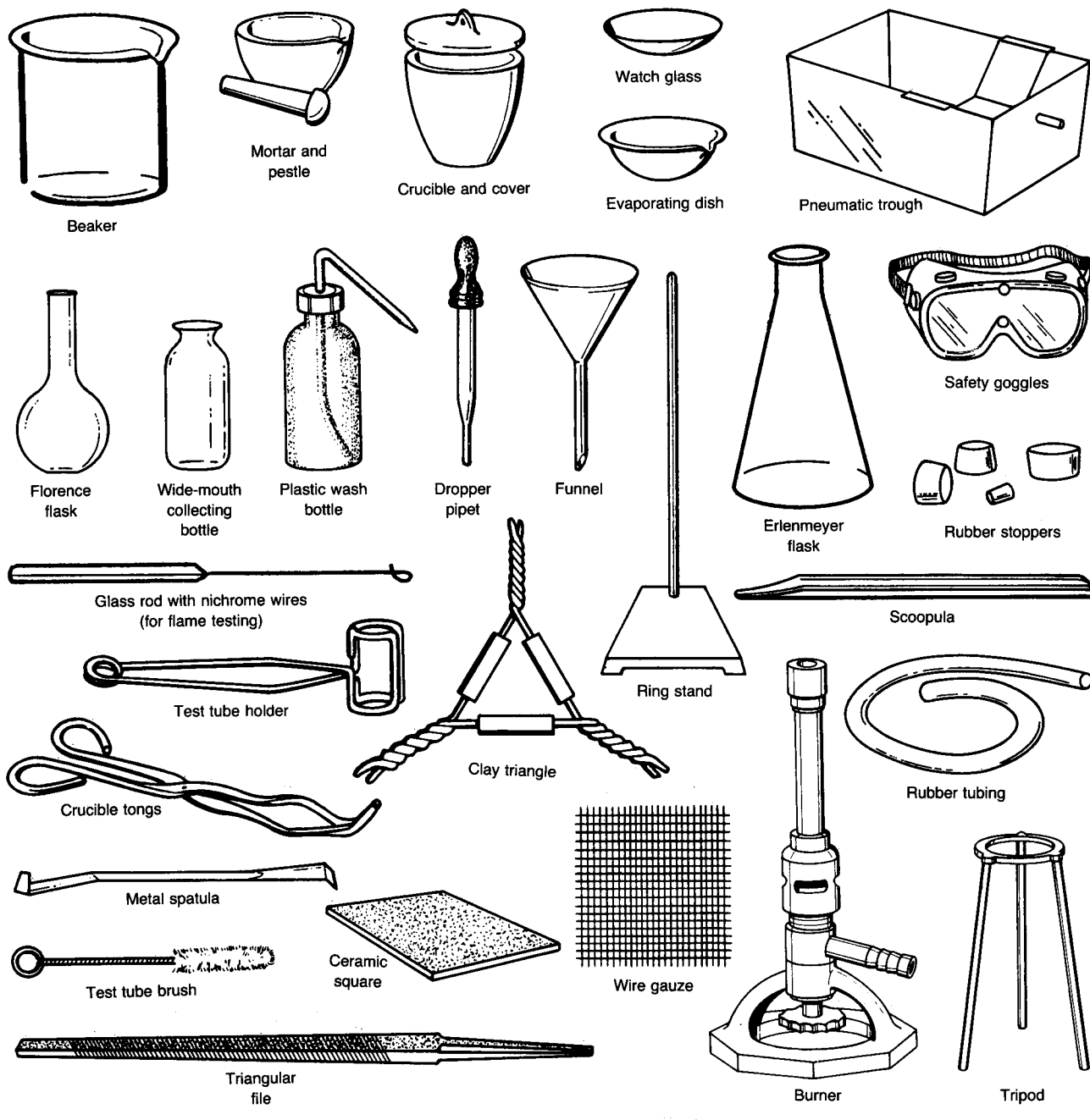

Beaker: glass or plastic; common sizes are 50-mL, 100-mL, 250-mL, 400-mL; glass beakers may be heated.

Buret: glass; common sizes are 25-mL, and 50-mL; used to measure volumes of solutions in titrations.

Ceramic square: used under hot apparatus or glassware.

Clamps: the following types of clamps may be fastened to support apparatus: buret/test-tube clamp, clamp holder, double buret clamp, ring clamp, 3-pronged jaw clamp.

Clay triangle: wire frame with porcelain supports, used to support a crucible.

Condenser: glass; used in distillation procedures.

Crucible and cover: porcelain, used to heat small amounts of solid substances at high temperatures.

Crucible tongs: iron or nickel, used to pick up and hold small items.

Dropper pipet: glass tip with rubber bulb, used to transfer small volumes of liquid.

Erlenmeyer flask: glass, common sizes are 100-mL, 250-mL; may be heated, used in titrations.

Evaporating dish: porcelain, used to contain small volumes of liquid being evaporated.

Florence flask: glass, common sizes are 125-mL, 250-mL, 500-mL, may be heated, used in making and for storing solutions.

Forceps: metal, used to hold or pick up small objects.

Funnel: glass or plastic, common size holds 12.5-cm diameter filter paper.

Gas burner: constructed of metal; connected to a gas supply with rubber tubing; used to heat chemicals (dry or in solution) in beakers, test tubes, and crucibles.

Gas collecting tube: glass, marked in mL intervals; used to measure gas volumes.

Glass rod with nichrome wire: used in flame tests.

Graduated cylinder: glass or plastic, common sizes are 10-mL, 50-mL, 100-mL, used to measure approximate volumes; must not be heated.

Graduated pipet: glass, common sizes are 10-mL, 25-mL; used to measure solution volumes; less accurate than a volumetric pipet.

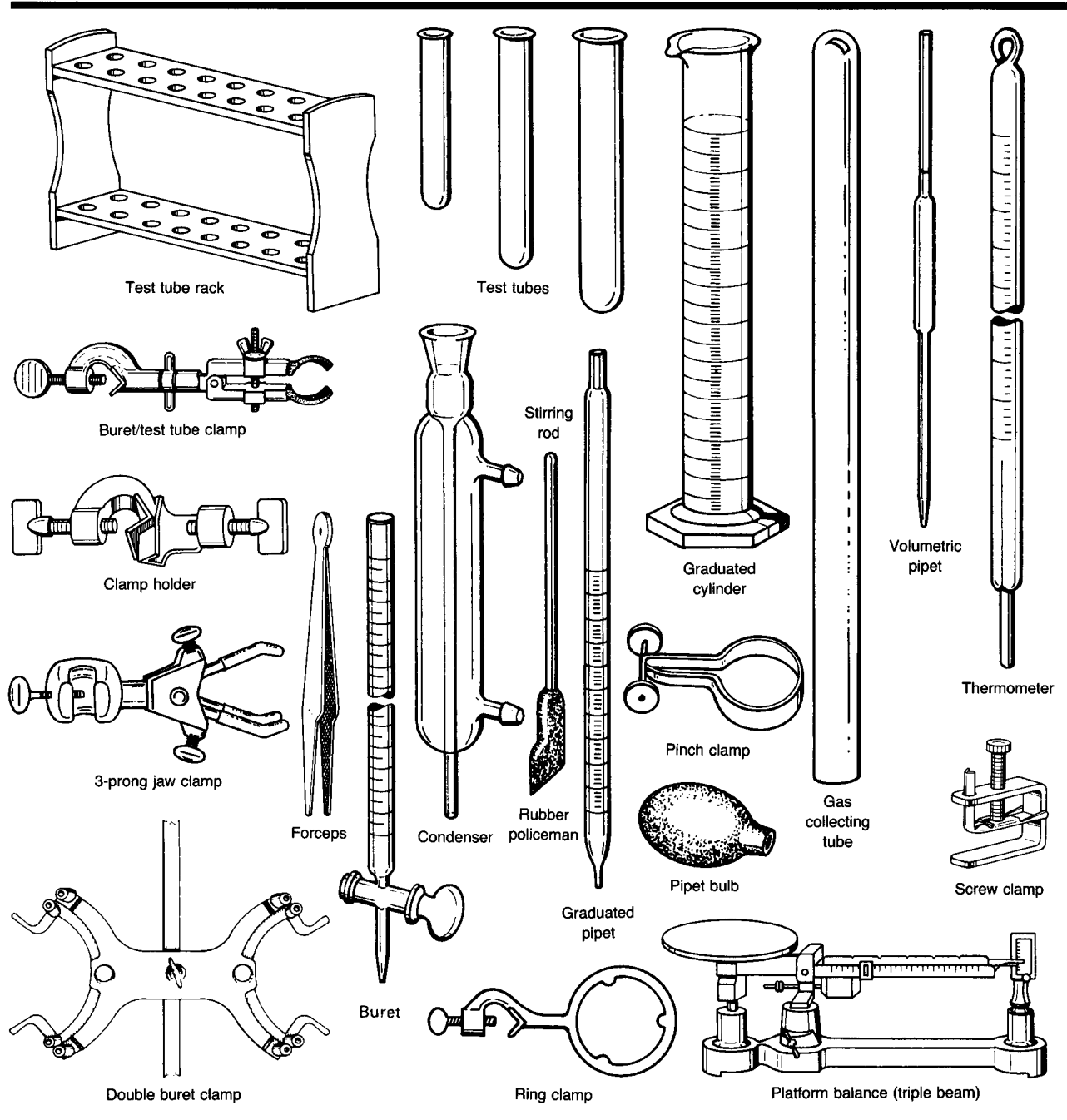

Mortar and pestle: porcelain, may be used to grind crystals and lumpy chemicals to a powder.

Pipet bulb: rubber, used in filling a pipet with a solution, a pipet must never be filled by mouth.

Plastic wash bottle: flexible plastic, squeeze sides to dispense water.

Platform balance: also known as a triple beam balance.

Pneumatic trough: galvanized container with shelf, used in experiments where a gas is collected.

Ringstand: metal rod fixed upright in a heavy metal base; has many uses as a support.

Rubber stoppers: several sizes.

Rubber tubing: used to connect apparatus so as to transfer liquids or gases.

Safety goggles: plastic; must be worn at all times while working in the laboratory.

Screw clamp, pinch clamp: metal, used to block off rubber tubing.

Spatula, scoopula: metal or porcelain; used to transfer solid chemicals; the scoopula has a larger capacity.

Stirring rod and rubber policeman: glass with rubber sleeve; used to stir, assist in pouring liquids, and for removing precipitates from a container.

Test tube brush: bristles with wire handle, used to scrub small diameter glassware.

Test tube holder: spring metal, used to hold test tubes or glass tubing.

Test tube rack: wood or plastic, holds test tubes in a vertical position.

Test tubes: glass, common sizes small (13 mm x 100 mm), medium (20 mm x 150 mm), large (25 mm x 200 mm), may be heated.

Thermometer: mercury in glass, common range -10°C to 110°C .

Triangular file: metal, used to scratch glass tubing prior to breaking to desired length.

Tripod: iron, used to support containers of chemicals above the flame of a burner.

Volumetric pipet: glass, common sizes are 10-mL, 25-mL, used to measure solution volumes accurately, must not be heated.

Watch glass: glass, used to cover an evaporating dish or beaker.

Wide-mouth bottle: glass, used with pneumatic trough.

Wire gauze: used to spread the heat of a burner flame.

Safe Laboratory Techniques

Pouring Liquids

- Always read the label on a reagent bottle before using its contents.
- Always wear safety goggles when handling chemicals.
- Never touch chemicals with your hands.
- Never return unused chemicals to their original containers. To avoid waste, do not take excessive amounts of reagents.

Follow this procedure when pouring liquids.

1. Use the back of your fingers to remove the stopper from a reagent bottle. Hold the stopper between your fingers until the transfer of liquid is complete. Do not place the stopper on your workbench.
2. Grasp the container from which you are pouring with the palm of your hand covering the label.
- 3a. When you are transferring a liquid to a test tube or measuring cylinder, the container should be held at eye level. Pour the liquid slowly until the correct volume has been transferred.
- 3b. When you are pouring a liquid from a reagent bottle into a beaker, the reagent should be poured slowly down a glass stirring rod (Figure 1). When you are transferring a liquid from one beaker to another, you can hold the stirring rod and beaker in one hand.

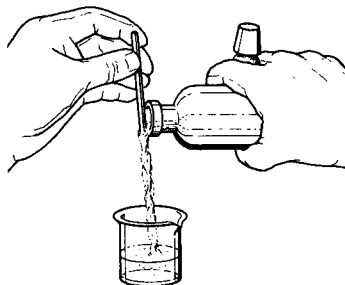

Figure 1. Pouring from a reagent bottle into a beaker.

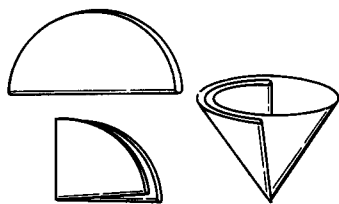

Figure 2. Folding the filter paper.

Filtering a Mixture

Sometimes it is necessary to separate a solid (for example, a precipitate) from a liquid. The most common method of separating such a mixture is filtration.

1. Fold a filter paper circle in half and then quarters. Open the folded paper to form a cone with one thickness of paper on one side and three thicknesses on the other (Figure 2).
2. Put the paper cone in a filter funnel. Place the funnel in an iron ring clamped to a ring stand. Moisten the filter paper with a small volume of distilled water, and gently press the paper against the sides of the funnel to give a good fit. (If the correct size of filter paper has been used, the top edge of the cone will be just below the rim of the filter funnel.)
3. Place a beaker beneath the funnel to collect the filtrate. The tip of the funnel should touch the inside surface of the beaker and extend about one inch below the rim (Figure 3).
4. Decant the liquid from the solid (precipitate) by pouring it down a glass stirring rod into the funnel. Be careful to keep the liquid below the top edge of the cone of filter paper at all times; the liquid must not overflow. Finally, use a jet of distilled water from a wash bottle to wash the solid (precipitate) into the filter.
5. When the filtration is complete, wash the solid residue on the filter paper with distilled water to remove traces of solvent. Dry the solid.
6. If the filtrate contains a dissolved salt it may be recovered by evaporation if desired.

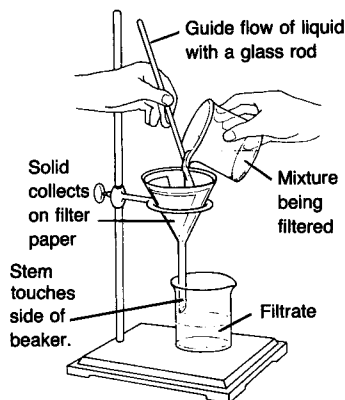

Figure 3. Filtration assembly.

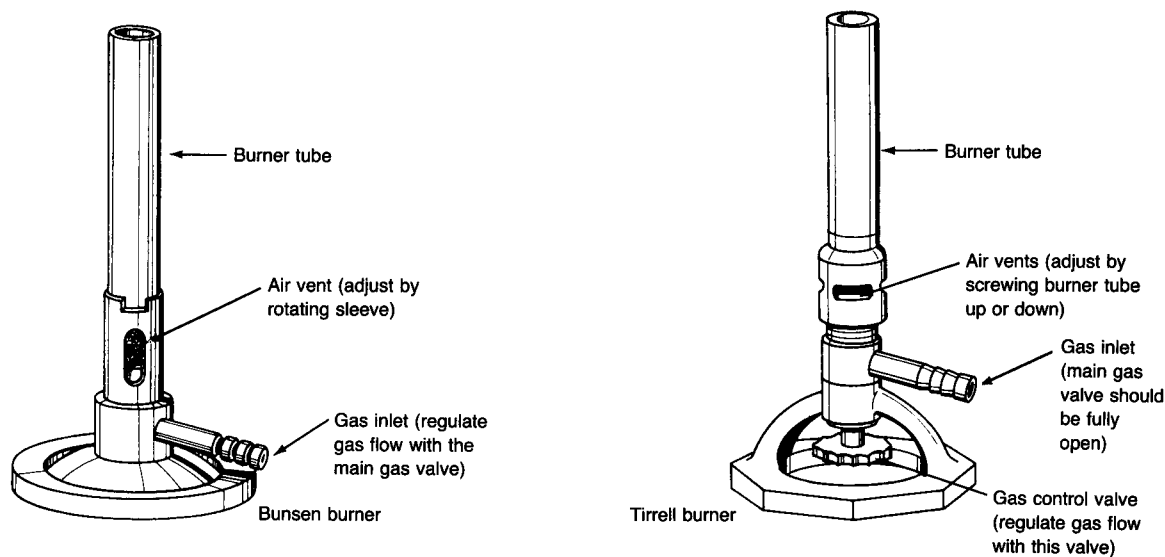
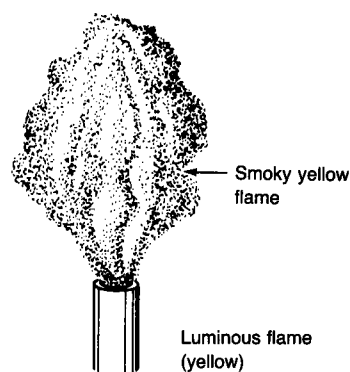

Figure 4. Laboratory gas burners.

Using a Gas Burner

Laboratory gas burners produce various kinds of flames when different mixtures of gas and air are burned. The two most common models are the Bunsen burner and the Tirrell burner. Both have adjustable air vents; the Tirrell burner also has a gas control valve in its base (Figure 4).

1. Examine your laboratory burner. Determine which model you have.
2. Connect the burner to the gas supply with rubber tubing.
3. Close the air vents. If your model is a Tirrell burner also close the gas control valve at the base of the burner.
4. Hold a lighted match at the top of the burner tube and turn on the gas supply. Do this by opening the main gas supply valve located on top of the nozzle to which you attached the rubber tubing. (If your model is a Tirrell burner, open the gas control valve at the base approximately $\frac{1}{2}$ -turn after opening the main gas supply valve.) You should get a yellow or luminous flame (Figure 5). When a Tirrell burner is used, the main gas supply valve should be opened fully and the gas flow regulated by the gas control valve. Gas supply to a Bunsen burner is controlled by the main gas valve.
5. Open the air vents slowly, to admit more air into the flame, to produce a light blue (nonluminous) cone-shaped flame. If the flame “blows out” after lighting, the gas supply should be reduced.
6. Adjust the air vents and gas supply to produce the desired size of flame. For most laboratory work the blue inner cone of the flame should be about one inch high and free of yellow color. If you want a smaller flame, close the air vent slightly and reduce the gas supply. You will learn how to control the burner flame by trial and error.
7. Turn the burner off at the main gas supply valve when done.



a. air vents closed

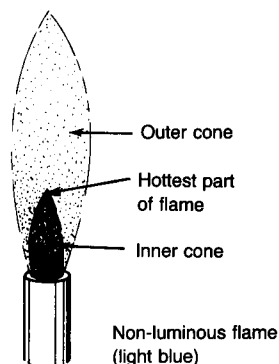

b. air vents open

Figure 5. Burner flame characteristics.

Caution: Confine long hair and loose clothing when using a gas burner. Do not reach over a burner. Ensure that flammables are not being used when a burner is lit. Never leave a lit burner unattended. Know the location of fire extinguishers, the fire blanket, and safety shower.

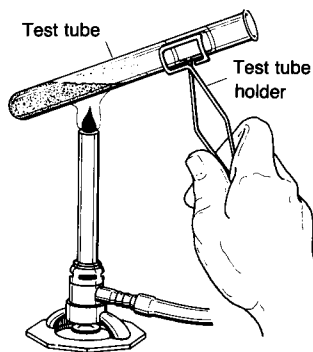

Figure 6. Heating a liquid in a test tube.

Heating Liquids

Heating a liquid in a test tube. The correct procedure for heating liquids in the laboratory is important to laboratory safety.

1. Adjust your gas burner to give a gentle blue flame.
2. Fill a test tube one-third full with the liquid to be heated.
3. Grasp the test tube with a test tube holder near the upper end of the tube.
4. Hold the test tube in a slanting position in the flame, and gently heat the tube a short distance below the surface of the liquid (Figure 6).
5. Shake the tube gently as it is being heated, until the liquid boils or reaches the desired temperature.

Caution: *Never point the open end of a test tube you are heating either toward yourself or anyone working nearby. Never heat the bottom of the test tube.*

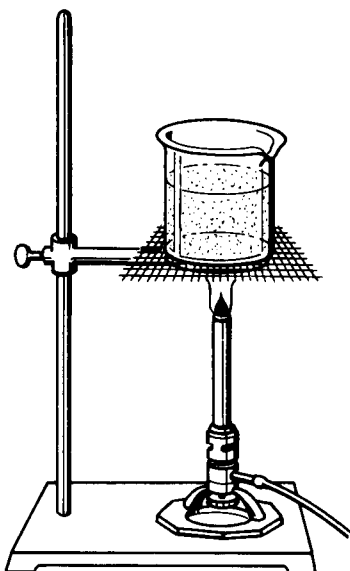

Figure 7. Heating a liquid in a beaker.

Heating a liquid in a beaker. Many laboratory experiments require the use of a hot-water or boiling-water bath. This procedure describes how to assemble a water bath.

1. Fasten an iron ring securely to a ring stand so that it is about two to four centimeters above the top of a gas burner placed on the ring stand base.
2. Place a 250-mL beaker one-half filled with water on a wire gauze resting on the iron ring (Figure 7).
3. Light your gas burner and adjust it to give a hot flame.
4. Place the burner beneath the wire gauze. For a slower rate of heating, reduce the intensity of the burner flame.

Caution: *Never heat plastic beakers or graduated glassware in a burner flame. Never let a boiling water bath boil dry; add water to it as necessary.*

Inserting Glass Tubing

In many experimental procedures you are required to insert a thermometer or a length of glass tubing into a hole in a rubber stopper. It is essential that you know the correct way to do this. Otherwise serious injury may result.

1. Lubricate the end of the glass tubing with a few drops of water, washing-up liquid, glycerol, or vegetable oil.
2. Hold the glass tubing close to where it enters the hole in the rubber stopper. Protect your hands with work gloves or pieces of cloth.
3. Ease the tubing into the hole with a gentle twisting motion. Push the tubing through the hole as far as is required. Do not use force!
4. Wipe excess lubricating material from the tubing before continuing with the experiment.
5. If the glass tubing is to be removed from the stopper it should be done immediately after the experiment is completed.

Caution: *The end of the glass tubing should be fire-polished or smoothed with emery cloth before being inserted into a rubber stopper. Do not try to bend the glass tubing—it will break. Ensure that the palm of the hand holding the rubber stopper is not in line with the emerging glass tube.*

Measuring Mass

In many experiments you are required to determine the mass of a chemical used or produced in a reaction. An object's mass is determined by measuring it on a balance. When we determine the mass of an object, we are comparing its mass with a known mass. In the SI the base unit of mass is the kilogram.

There are many types of laboratory balances. The one used most frequently in schools is the centigram balance (Figure 8). The following general rules apply to the use of all balances.

- Check the balance before you start weighing. The balance pan should be empty and clean, and all masses (or dials) should be set on zero. The balance must be level. Check the bubble level on the base. See your teacher if you need assistance with checking your balance.
- Objects to be weighed directly on the balance pan must be clean, dry, and at room temperature. Solid chemicals and liquids must never be put directly on the balance pan. Liquid samples should be placed in beakers or sealed containers. Solid chemicals can be conveniently placed in beakers, disposable plastic weighing boats, or on 10-cm squares made of glossy paper.
- The balance is a precision instrument that must be handled with care. To avoid damaging it, always be sure that the balance is in an arrested position when objects are placed on or removed from the pan. Always turn all dials slowly.
- Never move or jar either a balance or the balance table.
- If you spill a chemical on or near the balance, clean it up immediately. If in doubt, inform your teacher. A camel-hair brush is usually provided to wipe minute traces of solid from the balance pan before you use it.
- Never attempt to weigh an object with a mass greater than the maximum capacity of the balance.
- When you finish weighing, return all the masses to zero, and make sure the balance pan is clean.

Do not attempt to use a balance until your teacher has demonstrated the proper technique.

Figure 8. The centigram balance.

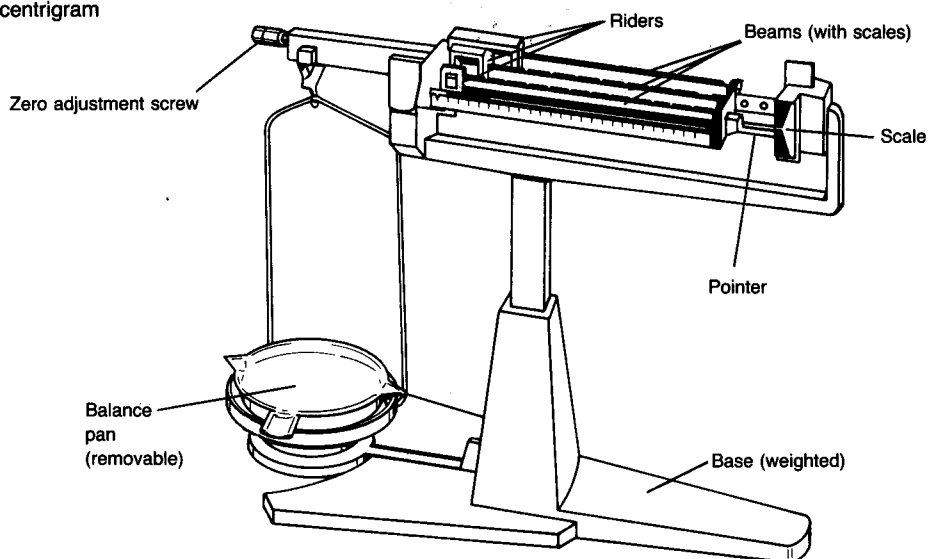

Using a Centigram Balance

1. Examine a centigram balance. The maximum capacity for this balance is 300 g and the sensitivity (limit of detection) is 0.01 g. The balance has four beams and four riders.
2. Move all the riders to their zero points (to the left side of their respective beams). Ensure that the riders rest in the notches on the beams.
3. Check to see that the beam is balanced. The pointer should move the same distance above and below the zero line on the scale or come to rest at the zero line. Use the zero adjustment screw if necessary. Always zero the balance before you begin any weighing. When the balance has been checked and adjusted you are ready to begin weighing.
4. Place the object whose mass is to be determined on the pan. (It must be dry and at room temperature (see the general rules).)
5. Slide the riders gently along the beams, one at a time, beginning with the largest. If a beam is notched be sure that the rider is in a notch. Note that all the beams have notches except the one carrying the smallest rider. When the added masses (the positions of the riders) is equal to the mass of the object on the pan then the pointer will be the zero line. It may also swing equal distances above and below the zero line.
6. To record the mass of the object, sum the masses indicated by the positions of the riders on their respective beams.
7. Return all riders to zero and remove your sample. Make sure that the balance pan is left clean.

Measuring Volume

Volume measurements are important in many experimental procedures. Sometimes volume measurements must be accurate; other times they can be approximate. Most volume measures in the laboratory are made using equipment calibrated in milliliters. Although some beakers have graduation marks, these marks are designed only for quick, rough estimates of volume. Accurate volumes must be measured with pipets, burets, or volumetric flasks.

Using a Graduated Cylinder

Half fill a 100-mL graduated cylinder with water, and set the cylinder on your laboratory bench. Examine the surface of the water. Notice how the surface curves upwards where the water contacts the cylinder walls. This curved surface is called a meniscus.

A volume measurement is always read at the bottom of the meniscus with your eye at the same level as the liquid surface. To make the meniscus more visible you can place your finger or a dark piece of paper behind and just below the meniscus while making the reading (Figure 9).

Graduated cylinders are available in many capacities. The 100-mL cylinder is marked in 1-mL divisions, and volumes can be estimated to the nearest 0.1mL. The last digit in these measurements is therefore significant but uncertain.

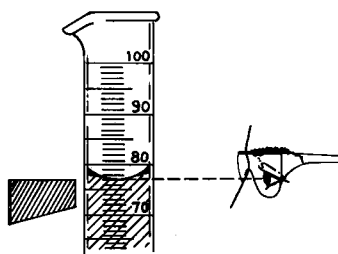

Figure 9. Reading volume in a graduated cylinder.

Using a Pipet

A pipet is used to accurately measure and deliver volumes of liquids. Two types are in common use: volumetric pipets and graduated or measuring pipets (Figure 10). The use of a volumetric pipet will be described. A volumetric pipet has a single calibration mark and delivers the volume printed on the bulb of the pipet at the temperature specified. (A graduated pipet has calibrations along the length of the pipet.) Volumes can be measured more accurately with a volumetric pipet than with a graduated pipet.

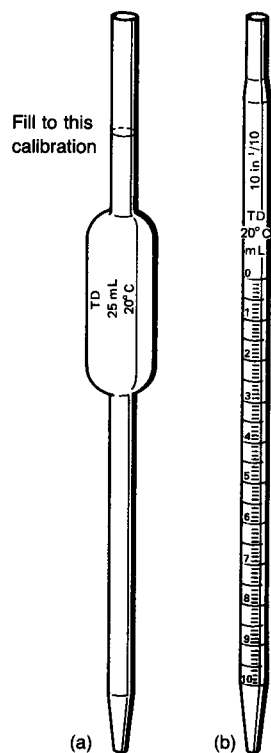
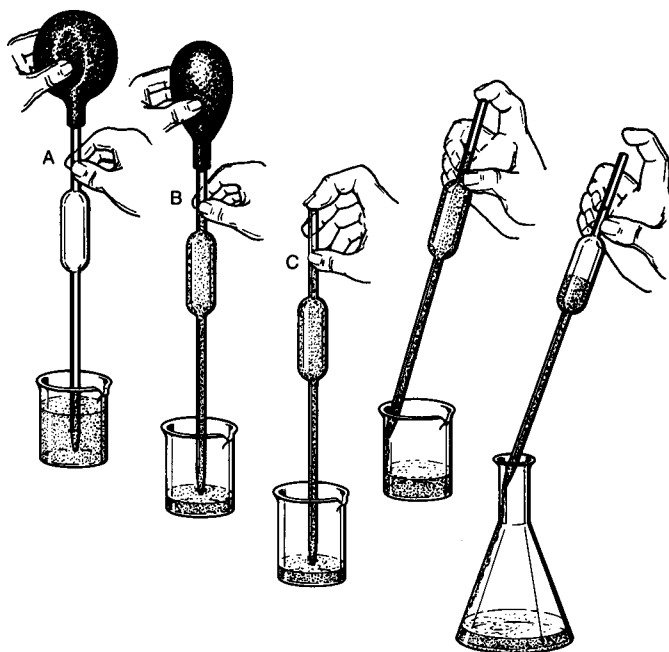

Figure 10. The volumetric pipet (a) and the measuring or graduated pipet (b).

1. Place the tip of the pipet below the surface of the liquid to be dispensed.
2. Compress a pipet bulb and press the hole in the bulb against the upper end of the pipet. **Caution:** *Never fill a pipet by applying suction with your mouth.* Never push the pipet bulb over the end of the pipet.
3. Slowly release pressure on the bulb so that liquid is drawn into the pipet to a level about 2 cm above the calibration mark.
4. Remove the bulb and simultaneously place your index finger over the end of the pipet. If you are right-handed you should hold the pipet in your right hand and the pipet bulb in your left (Figure 11).
5. Keep your index finger pressed firmly against the end. Withdraw the pipet from the liquid, and carefully wipe the outside of the stem with a paper towel.
6. Slowly reduce the pressure on your finger to allow the excess liquid to drain into a waste receiver until the bottom of the meniscus is at the calibration mark.
7. Now, deliver the remaining liquid in the pipet into the designated receiver. When releasing liquid from a volumetric pipet, let it drain completely. Wait 20 seconds, then touch the pipet tip to the side of the flask or surface of the liquid. This action will remove some, but not all, of the liquid in the tip. The pipet delivers the stated volume when this procedure is followed. A small amount of liquid remains in the tip. Do not blow this out into your receiver.

Figure 11. Filling and emptying a pipet.



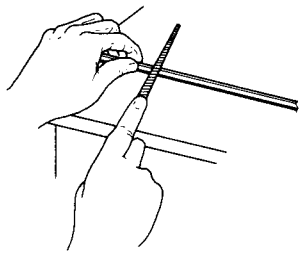

Figure 12.

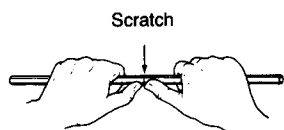

Figure 13.

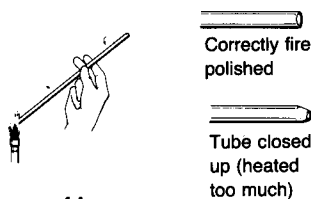
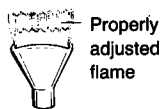
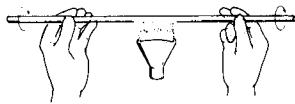

Figure 14.



Wing top on burner

Figure 15.



Heating glass tubing over a wing top prior to bending

Figure 16.

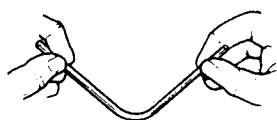

Bend and hold at desired angle

Figure 17.

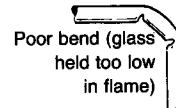
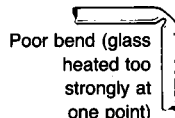
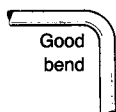

Figure 18.

Glassworking

Cutting and Fire Polishing

1. Place the glass tubing or glass rod on a flat surface (such as the laboratory bench).
2. Hold the glass tightly with one hand close to the area to be cut.
3. Using a firm stroke, make a *single* deep scratch with a triangular file (Figure 12).

CAUTION: Do not use a sawing motion or repeated scratching.

4. Grasp the glass in both hands with the scratch facing away from you and both thumbs directly behind the scratch (Figure 13).
5. Push firmly with the thumbs and pull with your fingers. The glass should snap with a clean break.

CAUTION: Be careful with the cut ends of the glass. They may be sharp and jagged. Do not attempt to break glass tubing having an outside diameter greater than 6 mm.

6. The cut ends of the glass tubing should be fire polished to make the tubing safe to handle. Rotate one end of the glass tube in the hottest part of a burner flame until the sharp edges have softened and become rounded (Figure 14).

CAUTION: Do not hold the tubing in the flame too long. If you do, the hole in the tube will close.

7. Place the hot glass on a wire gauze square to cool.

CAUTION: Hot glass and cold glass look alike. Make sure one end of a piece of glass has cooled before you attempt to fire polish the other end.

Bending Glass Tubing

1. Put a wing top or flame spreader on your gas burner.
2. Light the burner and adjust the flame to give an even blue (hot) flame across the wing top (Figure 15).
3. Grasp a length of glass tubing that has been fire-polished at both ends. Hold the center of it lengthwise in the flame just at the top of the blue region. This is the hottest part of the flame (Figure 16).
4. Rotate the tubing in the flame to heat approximately a 5-cm section uniformly until it becomes soft and just begins to sag.
5. Remove the tubing from the flame and bend it to the desired shape in one movement (Figure 17). Examples of good and bad bends are shown in Figure 18.
6. When it has hardened, put the glass tubing on a wire gauze to cool.

CAUTION: Hot and cold glass look alike.